

Please check the examination details below before entering your candidate information

Candidate surname

Other names

Centre Number

Candidate Number

--	--	--	--	--

--	--	--	--

Pearson Edexcel International GCSE (9–1)

Time 2 hours

Paper

reference

4PH1/1P 4SD0/1P

Physics

UNIT: 4PH1

Science (Double Award) 4SD0

PAPER: 1P

You must have:

Ruler, calculator, protractor

Total Marks

Instructions

- Use **black** ink or ball-point pen.
- **Fill in the boxes** at the top of this page with your name, centre number and candidate number.
- Answer **all** questions.
- Answer the questions in the spaces provided
– *there may be more space than you need.*
- Show all the steps in any calculations and state the units.

Information

- The total mark for this paper is 110.
- The marks for **each** question are shown in brackets
– *use this as a guide as to how much time to spend on each question.*

Advice

- Read each question carefully before you start to answer it.
- Write your answers neatly and in good English.
- Try to answer every question.
- Check your answers if you have time at the end.

Turn over ►

P70705A

©2022 Pearson Education Ltd.

L:1/1/1/



Pearson

FORMULAE

You may find the following formulae useful.

energy transferred = current \times voltage \times time

$$E = I \times V \times t$$

$$\text{frequency} = \frac{1}{\text{time period}}$$

$$f = \frac{1}{T}$$

$$\text{power} = \frac{\text{work done}}{\text{time taken}}$$

$$P = \frac{W}{t}$$

$$\text{power} = \frac{\text{energy transferred}}{\text{time taken}}$$

$$P = \frac{W}{t}$$

$$\text{orbital speed} = \frac{2\pi \text{ orbital radius}}{\text{time period}}$$

$$v = \frac{2 \pi r}{T}$$

(final speed)² = (initial speed)² + (2 \times acceleration \times distance moved)

$$v^2 = u^2 + (2 \times a \times s)$$

pressure \times volume = constant

$$p_1 \times V_1 = p_2 \times V_2$$

$$\frac{\text{pressure}}{\text{temperature}} = \text{constant}$$

$$\frac{p_1}{T_1} = \frac{p_2}{T_2}$$

Where necessary, assume the acceleration of free fall, $g = 10 \text{ m/s}^2$.

DO NOT WRITE IN THIS AREA

DO NOT WRITE IN THIS AREA

DO NOT WRITE IN THIS AREA



Answer ALL questions.

Some questions must be answered with a cross in a box ☒. If you change your mind about an answer, put a line through the box ☒ and then mark your new answer with a cross ☒.

1 The region of space around a magnet is known as a magnetic field.

(a) Which of these diagrams correctly represents the magnetic field around a bar magnet?

(1)

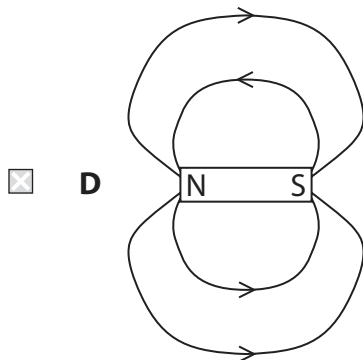
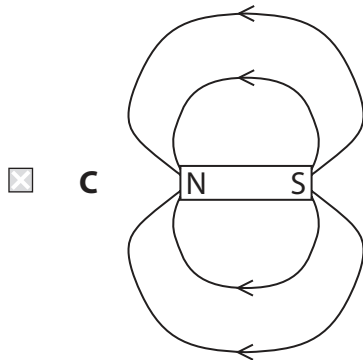
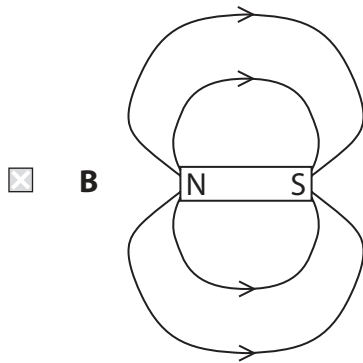
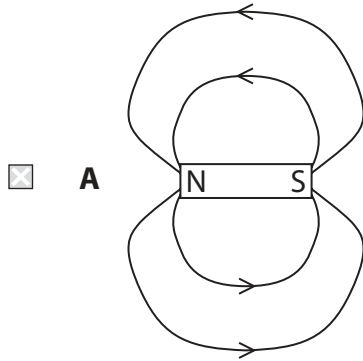

(b) The diagram shows two bar magnets placed close together.



(i) Which of these describes what happens to the two magnets?

(1)

- A** nothing happens
- B** they attract
- C** they repel
- D** they spin



(ii) Which of these magnet arrangements gives a uniform field between the poles?

(1)

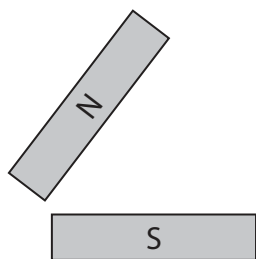

A



B

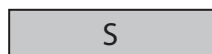

C

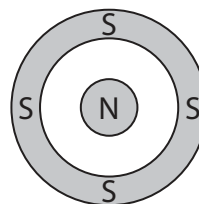

D

(c) State the name of a material that would be suitable for use as a permanent magnet.

(1)

.....

DO NOT WRITE IN THIS AREA

DO NOT WRITE IN THIS AREA

DO NOT WRITE IN THIS AREA



(d) Describe an investigation that could be used to determine the shape of the magnetic field around a bar magnet.

(3)

.....

.....

.....

.....

.....

.....

.....

.....

.....

.....

(Total for Question 1 = 7 marks)

DO NOT WRITE IN THIS AREA

DO NOT WRITE IN THIS AREA

DO NOT WRITE IN THIS AREA



DO NOT WRITE IN THIS AREA

DO NOT WRITE IN THIS AREA

DO NOT WRITE IN THIS AREA

BLANK PAGE



2 A scientist wants to determine the half-life of a radioactive isotope.

The scientist measures the count rate from the radioactive isotope.

(a) State how the scientist should correct the count rate for background radiation.

(1)

(b) The graph shows how the activity of the radioactive isotope varies with time.

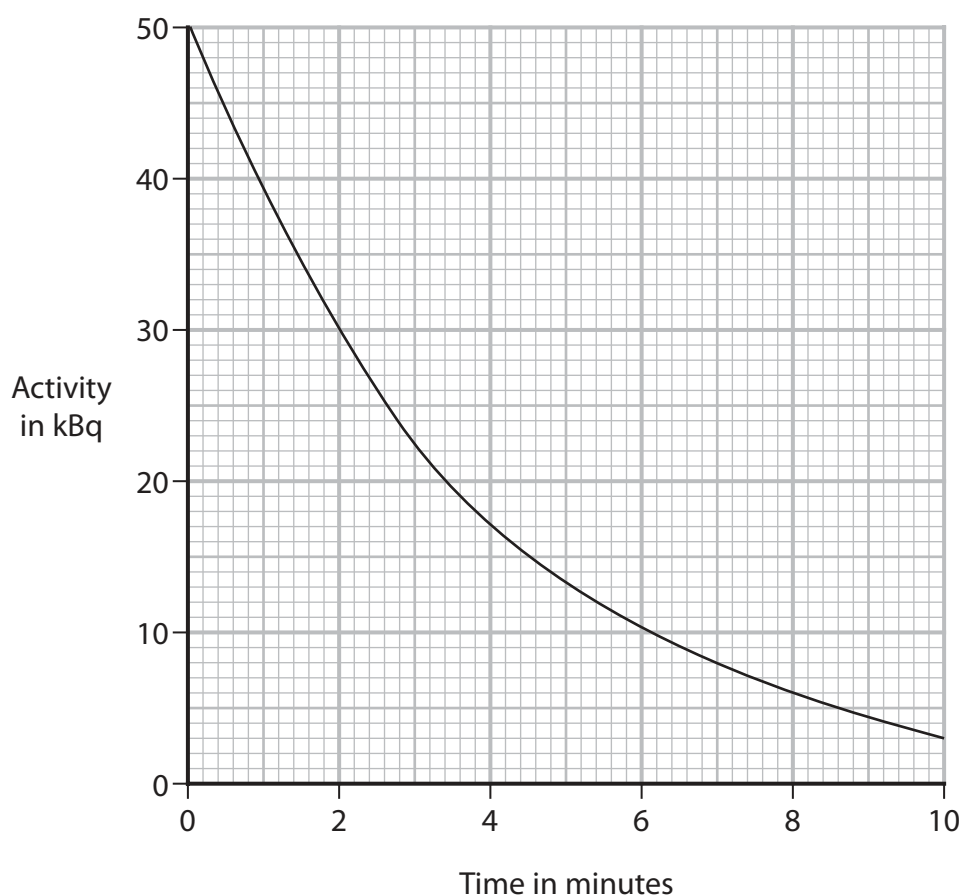

(i) Explain what is meant by the term **half-life**.

(2)



(ii) Use the graph to determine the half-life of this isotope.

(2)

half-life = minutes

(Total for Question 2 = 5 marks)

DO NOT WRITE IN THIS AREA

DO NOT WRITE IN THIS AREA

DO NOT WRITE IN THIS AREA



3 Wi-Fi signals are electromagnetic waves that can be transmitted at frequencies of 2.4 GHz and 5.2 GHz.

(a) (i) State a similarity of the Wi-Fi signals at 2.4 GHz and 5.2 GHz. (1)

(ii) The two Wi-Fi signals have different frequencies.
State another difference between the Wi-Fi signals. (1)

(b) (i) State the formula linking speed, frequency and wavelength. (1)

(ii) Calculate the wavelength of Wi-Fi signals transmitted at 5.2×10^9 Hz.
[speed of light = 3.0×10^8 m/s] (2)

wavelength = m

(c) (i) Which type of wave is a Wi-Fi signal? (1)

- A longitudinal
- B mechanical
- C sound
- D transverse



4 A student investigates the reflection of light by a plane mirror.

The student uses a ray box, a ruler, a pencil and a mirror.

(a) Name the apparatus that can be used to measure angles during the investigation.

(1)

(b) The diagram shows a ray of light directed to a point on the mirror.

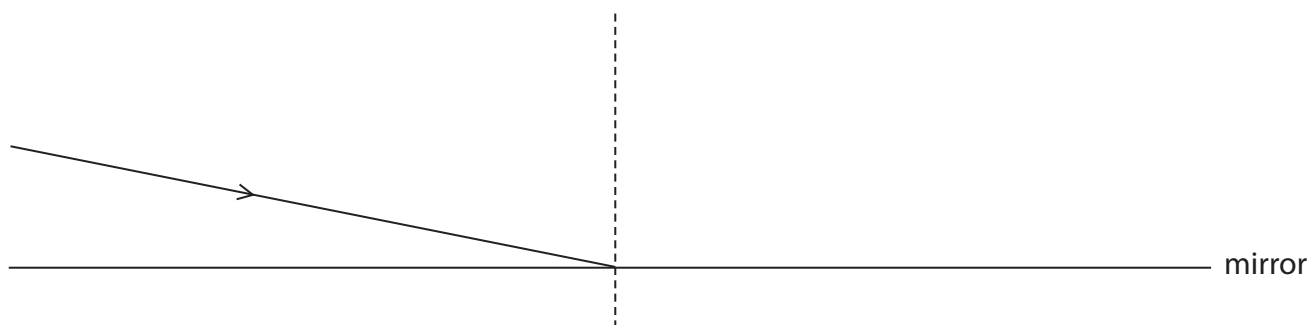

(i) Label the angle of incidence.

(1)

(ii) Measure the angle of incidence.

(1)

angle of incidence = degrees

(iii) Complete the diagram to show the ray reflected from the mirror.

(2)

(Total for Question 4 = 5 marks)



DO NOT WRITE IN THIS AREA

DO NOT WRITE IN THIS AREA

DO NOT WRITE IN THIS AREA

BLANK PAGE



P 7 0 7 0 5 A 0 1 3 3 6

5 A driver of a car sees an obstruction in the road ahead and must stop the car.

(a) (i) State the formula linking average speed, distance travelled and time taken. (1)

(ii) A car travels at 21 m/s.

The driver's reaction time is 0.14 seconds.

Calculate the distance travelled by the car during the driver's reaction time. (2)

distance = m

(b) The car experiences a braking force of 7600 N.

The car has a mass of 1200 kg.

(i) State the formula linking force, mass and acceleration. (1)

(ii) Calculate the acceleration of the car. (2)

acceleration = m/s²



(iii) Calculate the braking distance travelled as the speed of the car is reduced from 21 m/s to 0 m/s.

(3)

distance = m

(Total for Question 5 = 9 marks)

DO NOT WRITE IN THIS AREA

DO NOT WRITE IN THIS AREA

DO NOT WRITE IN THIS AREA



P 7 0 7 0 5 A 0 1 5 3 6

DO NOT WRITE IN THIS AREA

DO NOT WRITE IN THIS AREA

DO NOT WRITE IN THIS AREA

BLANK PAGE



DO NOT WRITE IN THIS AREA

DO NOT WRITE IN THIS AREA

DO NOT WRITE IN THIS AREA

6 (a) A person throws an object vertically upwards.

The speed-time graph shows how the speed of the object varies from the time it is thrown until reaching its maximum height.

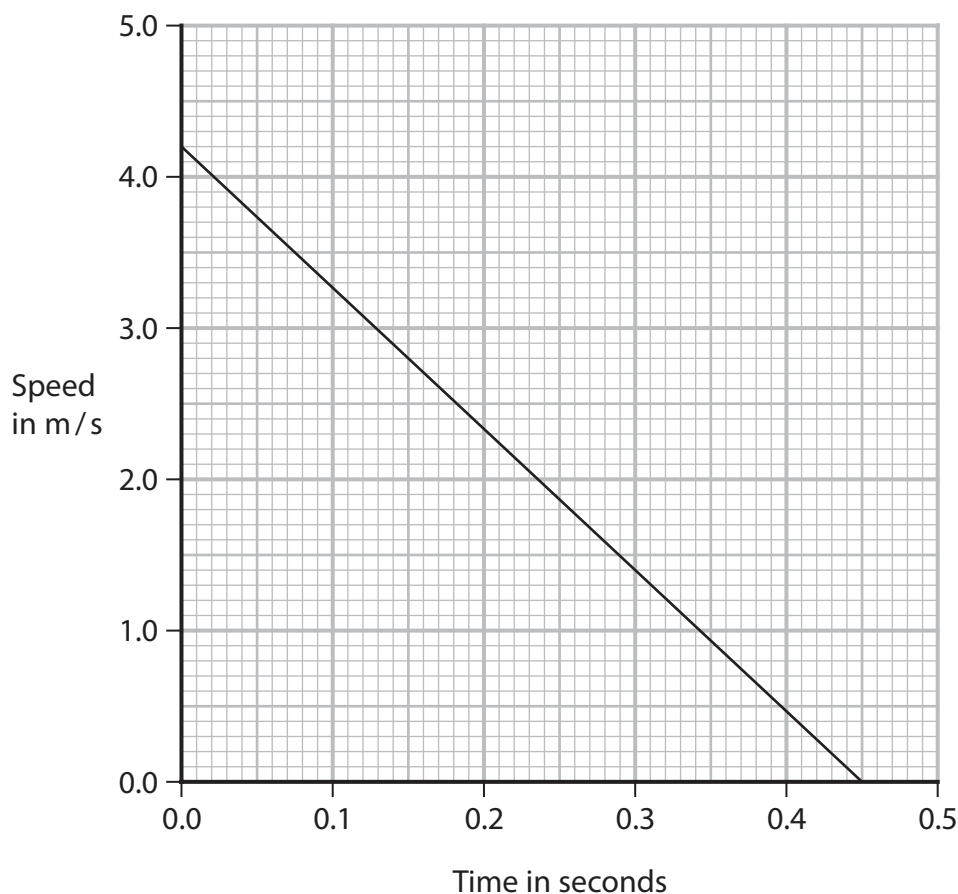

(i) Calculate the acceleration of the object. (3)

acceleration = m/s²

(ii) Calculate the distance the object travels to reach its maximum height. (3)

distance = m



(b) A different object is dropped from rest and begins to fall.

The graph shows how the speed of this object varies with time.

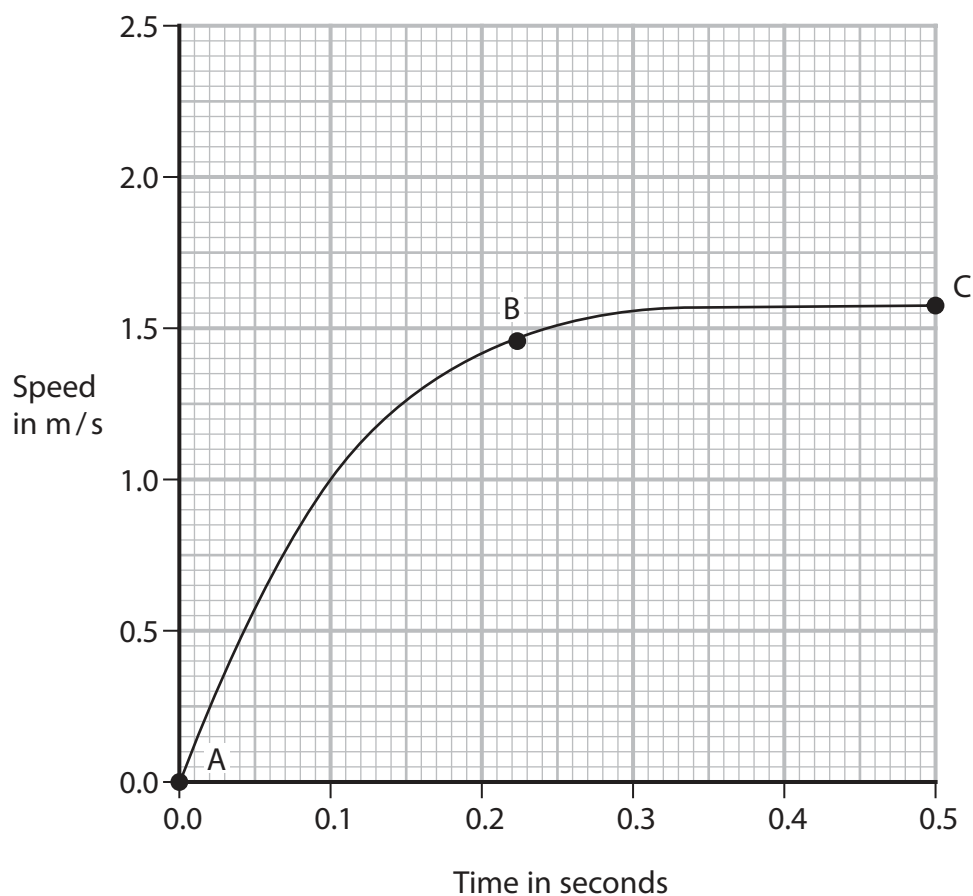

(i) Give the name of the two forces acting on the object as it falls.

(2)

1

2

(ii) Draw arrows on the diagram to show the forces acting on the object at B.

(3)

object



- 7 A teacher uses this circuit to investigate how the current in a circuit changes with the temperature of a room.

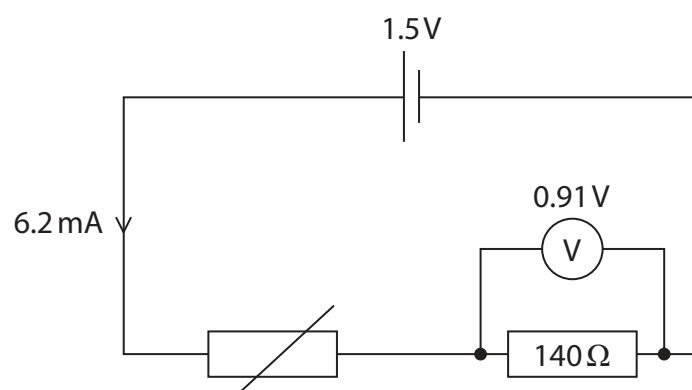

- (a) (i) Calculate the voltage across the thermistor.

(2)

voltage = V

- (ii) State the formula linking voltage, current and resistance.

(1)

- (iii) Calculate the resistance of the thermistor.

(3)

resistance = Ω



(b) The graph shows how the resistance of the thermistor changes with temperature.

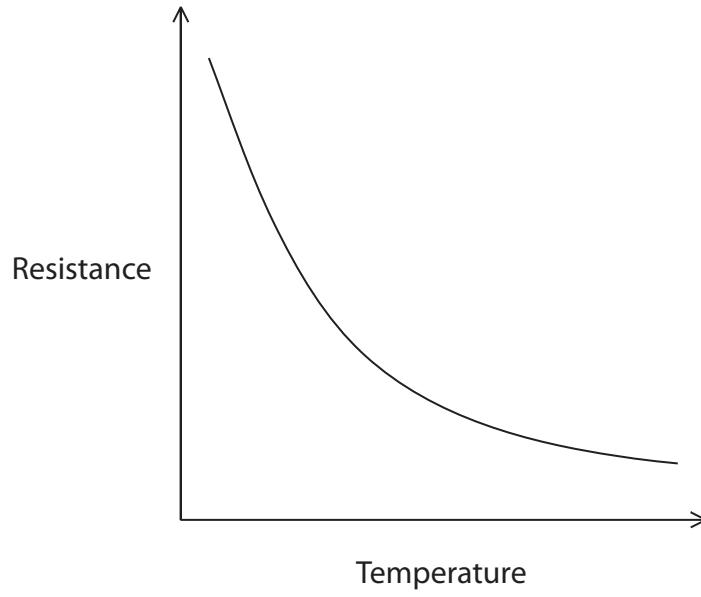

(i) Describe the relationship between the temperature and the resistance of the thermistor.

(2)

.....

.....

.....

.....

.....

.....

(ii) Explain how the reading on the voltmeter changes when the temperature of the room decreases.

(3)

.....

.....

.....

.....

.....

.....

(Total for Question 7 = 11 marks)

DO NOT WRITE IN THIS AREA

DO NOT WRITE IN THIS AREA

DO NOT WRITE IN THIS AREA



DO NOT WRITE IN THIS AREA

DO NOT WRITE IN THIS AREA

DO NOT WRITE IN THIS AREA

BLANK PAGE



- 8 Funcube-1 is a satellite that was launched into orbit around the Earth.



(Source: © Shutterstock)

- (a) The rocket carrying Funcube-1 burns fuel to accelerate upwards.

As the rocket burns fuel, the energy in its chemical store reduces and the energy in its kinetic store and gravitational store changes.

- (i) State how the kinetic store of the rocket changes as the rocket burns fuel. (1)

- (ii) State how the gravitational store of the rocket changes as the rocket burns fuel. (1)

- (b) The rocket engine stops burning fuel.

The rocket continues to go further away from the surface of the Earth.

The table gives some statements about the rocket's energy stores.

Add ticks (✓) to the table to show which two statements are correct. (2)

Statement	Correct (✓)
gravitational store increases	
gravitational store stays the same	
gravitational store decreases	
kinetic store increases	
kinetic store stays the same	
kinetic store decreases	

(c) Funcube-1 goes into a circular orbit above the surface of the Earth.

- (i) State the name of the force responsible for keeping Funcube-1 in orbit. (1)

(ii) Funcube-1 has an orbital radius of 7100 km and an orbital period of 5800 s.

- Calculate the orbital speed, in km/s, of Funcube-1. (2)

orbital speed = km/s



(d) Funcube-1 spins and is heated by the Sun.

The diagram shows two coloured metal bars attached to a face of Funcube-1.

The surface of one metal bar is dull and black.

The surface of the other metal bar is shiny and white.

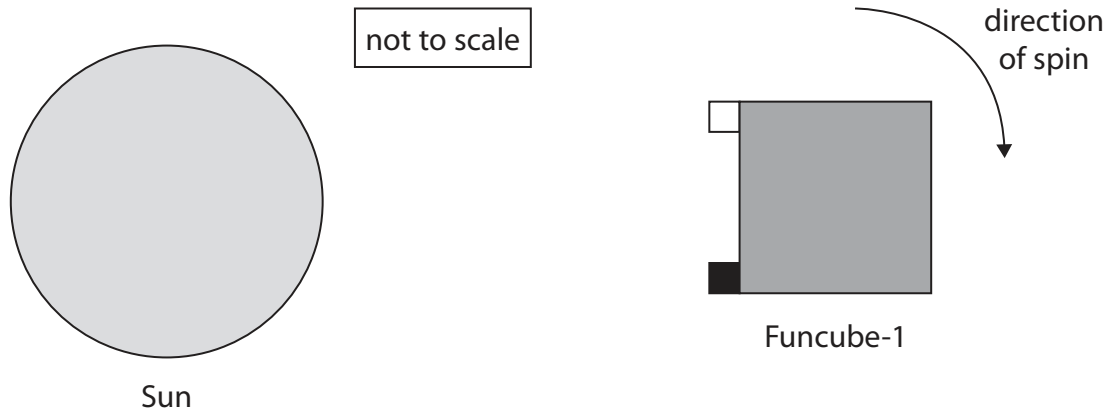

Temperature probes measure the temperature of each metal bar.

Use ideas about thermal energy transfer to explain how the temperature of each metal bar changes as Funcube-1 spins.

(4)

.....

.....

.....

.....

.....

.....

.....

.....

.....

.....

.....

.....

.....

.....

.....

.....

.....

.....

.....

.....

.....

.....

(Total for Question 8 = 11 marks)

DO NOT WRITE IN THIS AREA

DO NOT WRITE IN THIS AREA

DO NOT WRITE IN THIS AREA

BLANK PAGE



(b) The student calculates the force each mass applies to the spring.

The table shows the student's results.

Force in N	Extension in cm
0.0	0.0
1.0	2.5
2.0	5.0
3.0	9.8
4.0	10.0
5.0	12.5
6.0	15.5
7.0	19.5

- (i) Plot the student's results. (3)
- (ii) Draw a circle around the anomalous point. (1)
- (iii) Draw a line of best fit. (1)



DO NOT WRITE IN THIS AREA

DO NOT WRITE IN THIS AREA

DO NOT WRITE IN THIS AREA

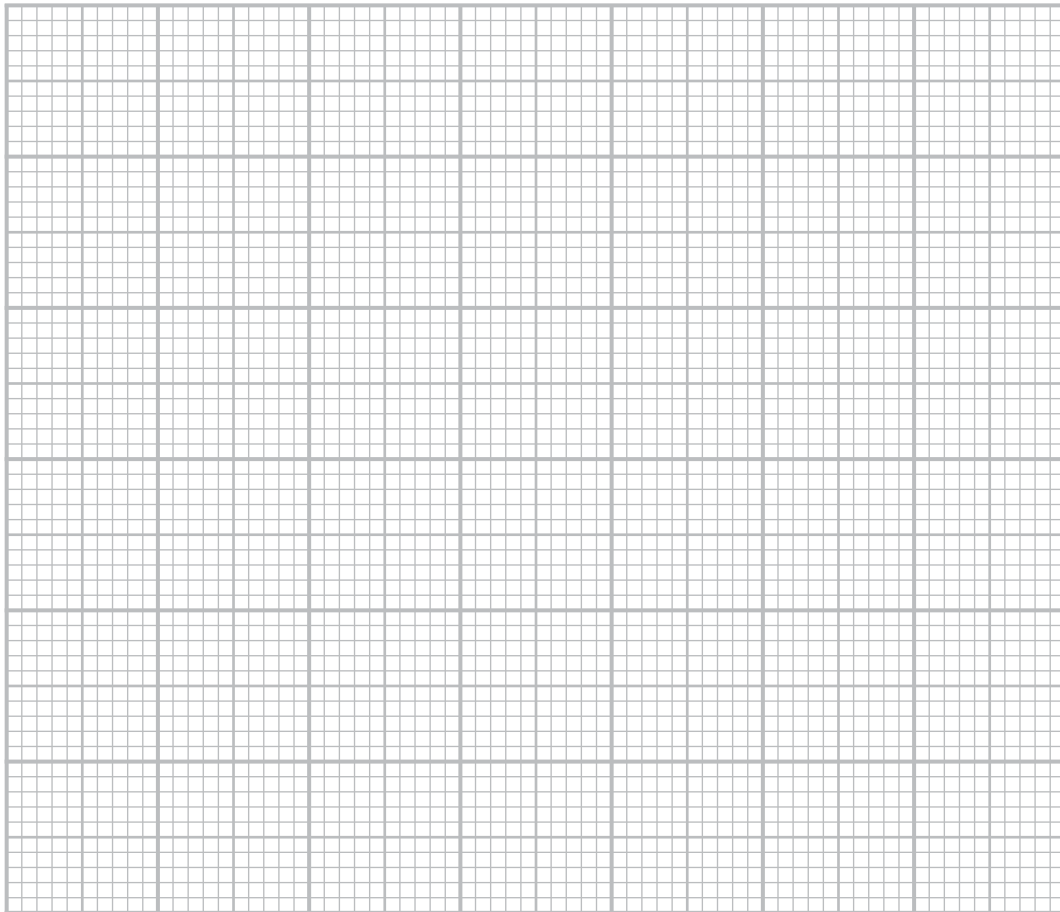

(iv) Explain whether the spring obeys Hooke's Law.

(3)

.....

.....

.....

.....

.....

.....

.....

(Total for Question 9 = 13 marks)



P 7 0 7 0 5 A 0 2 9 3 6

10 Diagram 1 shows a ray of violet light entering a prism.

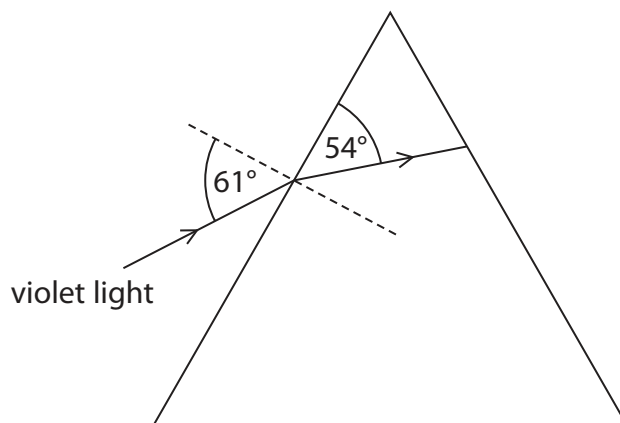

Diagram 1

(a) (i) Calculate the angle of refraction for the violet light.

(1)

angle of refraction = degrees

(ii) State the formula linking refractive index, angle of incidence and angle of refraction.

(1)

(iii) Calculate the refractive index of the prism for violet light.

Give your answer to 2 significant figures.

(3)

refractive index =



Diagram 2 shows rays of red light and violet light entering the same prism.

Red light has a longer wavelength than violet light.

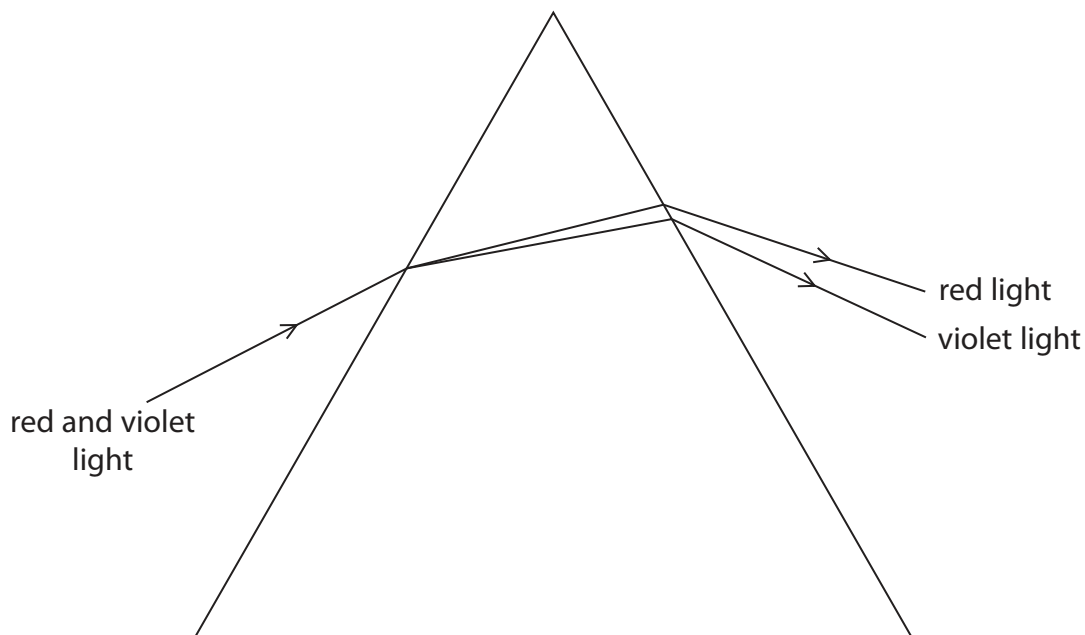

Diagram 2

(b) Deduce a possible relationship between the wavelength and the refractive index for colours of the visible spectrum.

(3)

.....

.....

.....

.....

.....

.....

.....

(Total for Question 10 = 8 marks)



11 Scientific balloons are tested in a laboratory before they are used.

(a) In the first test the pressure of the air inside the balloon is 120 kPa.

The balloon is sealed and has a volume of 92 m^3 .

(i) The pressure of the air inside the balloon is reduced to 64 kPa by reducing the external air pressure.

Calculate the new volume of the balloon.

(2)

volume = m^3

(ii) Give an assumption that is made in the calculation.

(1)



(b) The pressure of the air in the balloon is returned to 120 kPa.

The temperature of the air inside the balloon is 290 K.

The balloon is tested again, changing the temperature of the air and keeping the volume of the balloon constant.

(i) Explain why the pressure of the air in the balloon decreases when the temperature of the air decreases.

(3)

.....

.....

.....

.....

.....

.....

.....

.....

(ii) Calculate the temperature of the air when the pressure of the air in the balloon is 64 kPa.

Give your answer in kelvin.

(3)

temperature = K

(Total for Question 11 = 9 marks)



P 7 0 7 0 5 A 0 3 3 3 6

12 This question is about an electric fan.

- (a) A battery supplies a voltage of 12V and a current of 0.25 A to the fan.

The fan is switched on for 12 seconds and the fan gains 25 J in its kinetic energy store.

Calculate the efficiency of this energy transfer.

(4)

efficiency = %

- (b) The diagram shows part of the electric motor inside the fan.

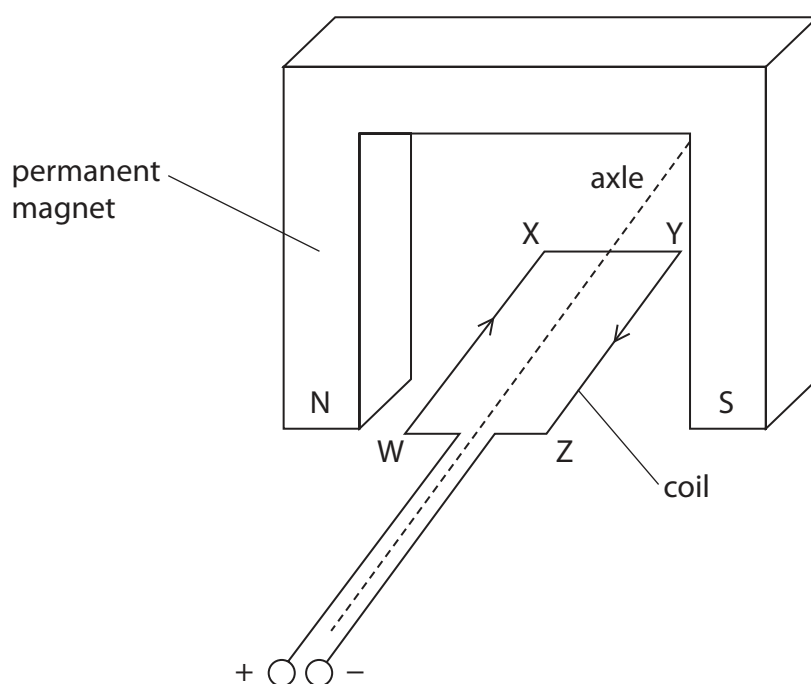

(i) Explain why the coil starts to rotate when there is a current in the coil.

(4)

.....

.....

.....

.....

.....

.....

.....

.....

(ii) Which side of the coil moves vertically upwards?

(1)

- A WX
- B XY
- C YZ
- D ZW

(Total for Question 12 = 9 marks)

TOTAL FOR PAPER = 110 MARKS

DO NOT WRITE IN THIS AREA

DO NOT WRITE IN THIS AREA

DO NOT WRITE IN THIS AREA



DO NOT WRITE IN THIS AREA

DO NOT WRITE IN THIS AREA

DO NOT WRITE IN THIS AREA

BLANK PAGE

